

TYPE A SILL

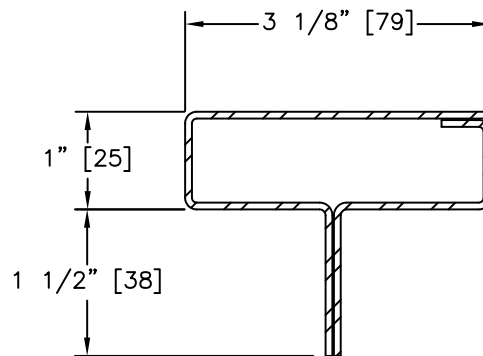

TYPE B SILL

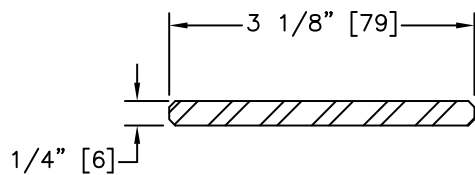

TYPE C SILL

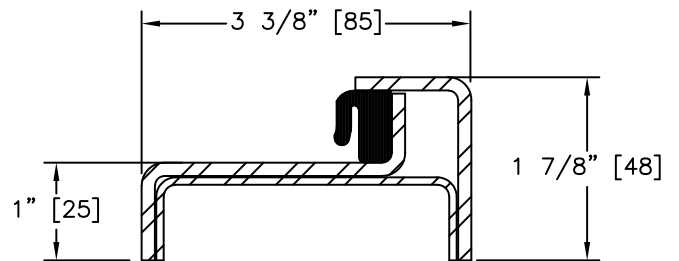

TYPE D SILL

GENERAL NOTES:

- 1) SPECIFY SILL MATERIAL – COLD ROLLED STEEL, STAINLESS STEEL OR ALUMINUM.
- 2) TYPE "B" SILL FLANGES TO BE UNDRILLED.
- 3) ALL DIMENSIONS AND DETAILS MAY BE MODIFIED TO FIT VARIOUS INSTALLATIONS.
- 4) FOR DOOR WITHOUT SILLS SPECIFY DISTANCE BOTTOM OF PANEL TO FINISHED FLOR OR DECK (UNDERCUT).